



**UNITED BRASS WORKS, INC**  
 714 S. Main St.. Randleman, N.C. 27317  
 Phone: 800/334-3035 Fax: 800/498-4696 [www.ubw.com](http://www.ubw.com)



## Model 946A 1/2" Short Shank Lower Fixture

**250 WSP @ 406°F Max  
400WOG**

**Rising Stem · Bronze Body  
Ductile Iron Hand Wheel**

**\*Contains lead. Not For Use In Water Systems  
Intended for Human Consumption\*  
CRN OCO7135.2C**

### MATERIAL LIST

NO.	DESCRIPTION	MATERIAL
1	Screw	Steel
2	Hand Wheel	Ductile Iron
3	Stem	Brass
4	Packing Nut	Brass
5	Bevel Washer (2)	Brass
6	Glass Washer	EPDM
7	Glass Washer Nut	Brass
8	Washer	Steel
9	Body	Bronze
10	Drain Cock	Brass
11	Packing	NAFG

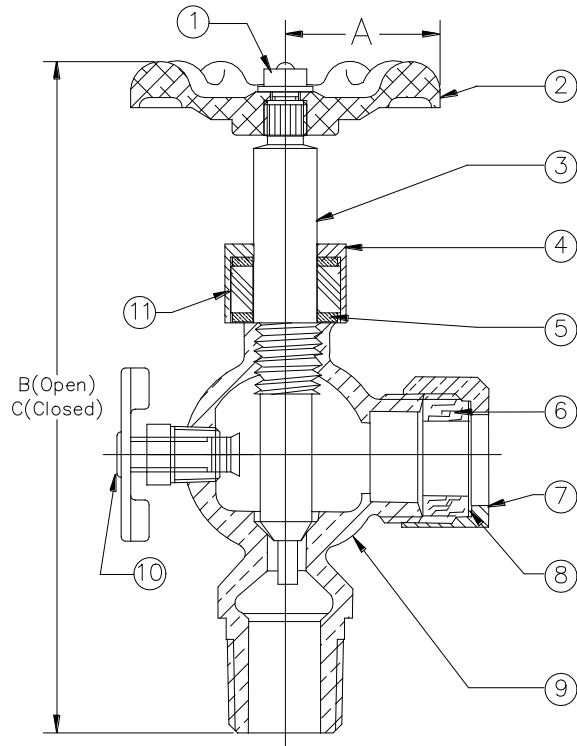

Size	1/2"
A	1.25
B	5.20
C	5.02
Ship Wt. (lbs.)	0.63
Qty. Per Carton	12

**\*Available With Plastic Hand  
Wheel as Part 946APW\***