



UNITED BRASS WORKS, INC.

714 S. Main St. Randleman, N.C. 27317

Tel: 800-334-3035 Fax: 800-498-4696 www.ubw.com



Model 905S 1/2"

Long Shank Upper Fixture With Ball Check

**250 WSP @ 406°F Max
400WOG**

**Rising Stem • Bronze Body
Ductile Iron Hand Wheel**

***Contains Lead. Not Intended for Use in Potable
Water Systems*
CRN OCO7135.2C**

MATERIAL LIST

NO.	DESCRIPTION	MATERIAL
1	Marker Disc	Steel
2	Hex Screw	Steel
3	Hand Wheel	Ductile Iron
4	Packing Nut	Brass
5	Metal Washer	Steel
6	Glass Washer	EPDM
7	Glass Washer Nut	Brass
8	Stem	Brass
9	Ball	Brass
10	Retaining Ring	Steel
11	Body	Bronze
12	Bevel Washer (2)	Brass
13	Packing	NAFG

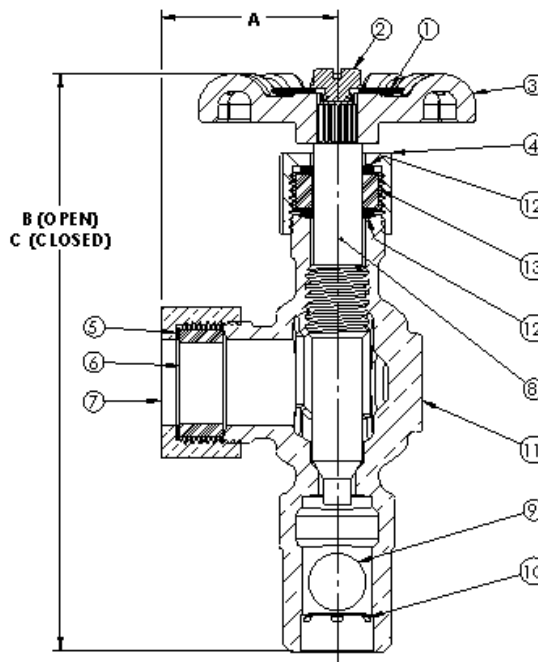

Size	1/2"
A	1.25
B	5.15
C	4.97
Ship Wt. (lbs.)	0.75
Qty. Per Carton	12

***Available with
Plastic Hand Wheel as
Part 905SPW***