



# UNITED BRASS WORKS, INC.

714 S. Main St., Randleman, NC 27317

Tel: 800-334-3035 Fax: 800-498-4696 www.ubw.com



## Model 125TB Valve

200 WOG

100% Pressure Tested

Threaded Ends • Rising Stem

Swivel Disc Holder

PTFE Disc • Integral Seat

Operating Temperature -50° C to +135° C

### MATERIAL LIST

NO.	DESCRIPTION	MATERIAL
1	Nut	Steel
2	Washer	Brass
3	Hand Wheel	Bronze
4	Packing Nut	Brass
5	Packing	NAFG
6	Bonnet (1/4" – 1") Bonnet (1 1/4" – 2")	Brass Bronze
7	Stem & Disc Holder	Brass
8	Body	Bronze
9	Disc	PTFE

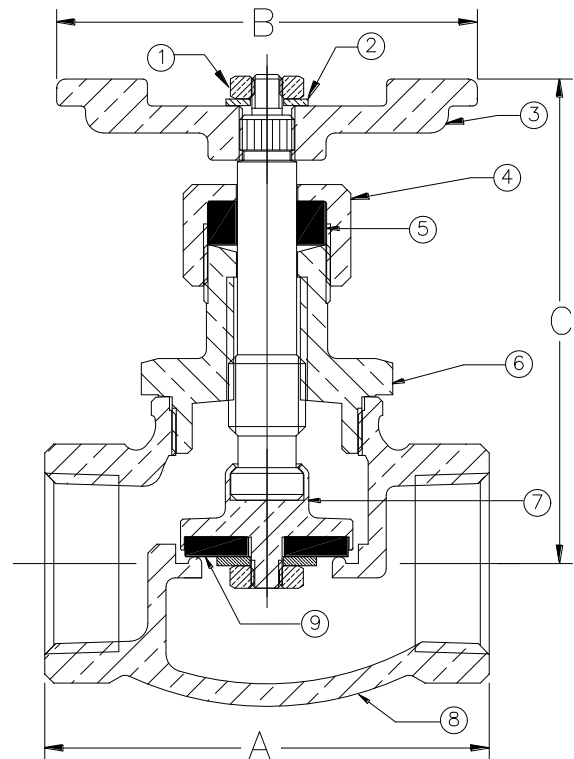

Size	1/4"	3/8"	1/2"	3/4"	1"	1 1/4"	1 1/2"	2"
A	1.75	1.84	2.22	2.47	2.97	3.56	4.06	4.69
B	2.90	2.90	2.90	2.90	2.90	3.50	3.50	3.50
C	2.88	3.13	3.38	3.50	4.25	4.75	5.50	5.50
Ship Wgt. (lbs.)	0.44	0.56	0.80	1.00	1.81	2.57	3.69	5.88
Qty. Per Ctn.	12	12	12	6	6	4	2	2
Qty. Per Case	60	60	72	60	36	24	12	12