



UNITED BRASS WORKS, INC.
 714 S. Main St. Randleman, N.C. 27317
 Tel: 800-334-3035 Fax: 800-498-4696 www.ubw.com



Model 127TNGB Sampler Valve



200 WOG • 100% Pressure Tested
Flange Inlet x Thread Outlet
ANSI Standard 150 Flange
No Gasket Groove • PTFE Disc
Bronze Hand Wheel
Operating Temperature -50° C to +135° C

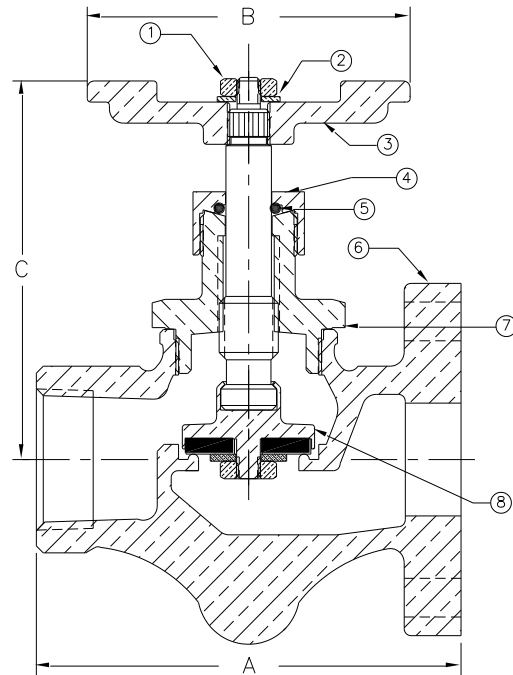

Material List		
No.	Description	Material
1	Nut	Steel
2	Washer	Brass
3	Hand Wheel	Bronze
4	O-Ring Nut	Brass
5	O-Ring	Mil Buna
6	Body	Bronze
7	Bonnet (1")	Brass
	Bonnet (2")	Bronze
8	Stem/Disc Assm.	Brass/PTFE

Size	A	B	C (Open)	C (Closed)	Bolt Circle	Bolt Hole	Weight
1"	3.81	2.94	3.75	3.31	3.13	0.625	3.93
2"	5.69	3.75	6.13	5.63	4.75	0.750	11.10