



UNITED BRASS WORKS, INC.

714 S. Main St. Randleman, N.C. 27317

Tel: 800-334-3035 Fax: 800-498-4696 www.ubw.com



Model 125TSS Globe Valve

200 WOG

100 % Pressure Tested

Threaded Ends • Rising Stem

PTFE Disc • 3/8" Sampler Device

Operating Temperature -50° C to 135° C

Sampler Port is on outlet side.

MATERIAL LIST		
NO.	DESCRIPTION	MATERIAL
1	Nut	Steel
2	Washer	Brass
3	Hand Wheel	Ductile or Zinc Die Cast
4	O-Ring Nut	Brass
5	O-Ring	Buna
6	Bonnet 1"	Brass
	Bonnet 1 1/2"-2"	Bronze
7	Stem & Disc Assembly	Brass with PTFE Disc
8	Body	Bronze
9	Sampler	86 3/8" (See Specs)

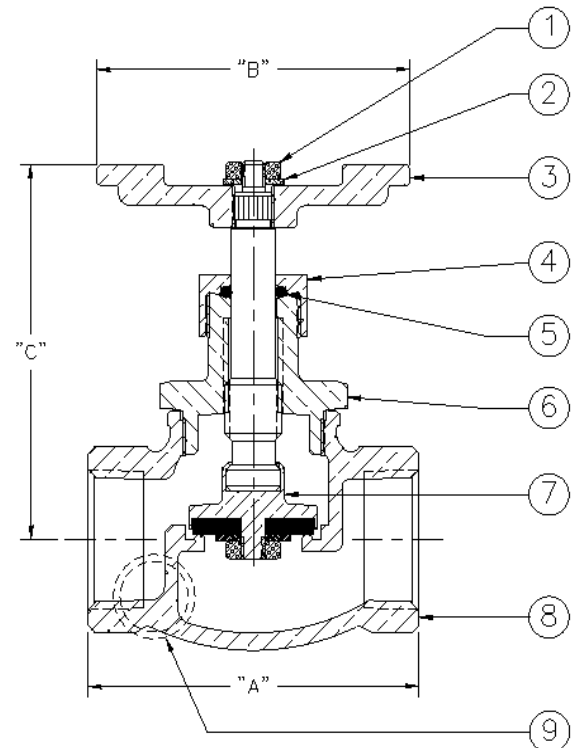

Size	A	B	C (Open)	C (Closed)	Weight
1"	3.03	2.94	4.38	4.00	2.47
1 1/2"	4.06	3.72	5.5	4.32	4.35
2"	4.66	3.56	7.25	6.50	6.28